

Fuji Magnetic starter

FJ Series, Starters with on-off pushbuttons

■ Features

- Compact and simple operation – Provided with ON-OFF pushbuttons, hence best suited for direct-on-line starting.
- Superior motor protection – Built-in highly reliable thermal overload relay is designed to give motor complete protection against overcurrent.



■ Type number nomenclature

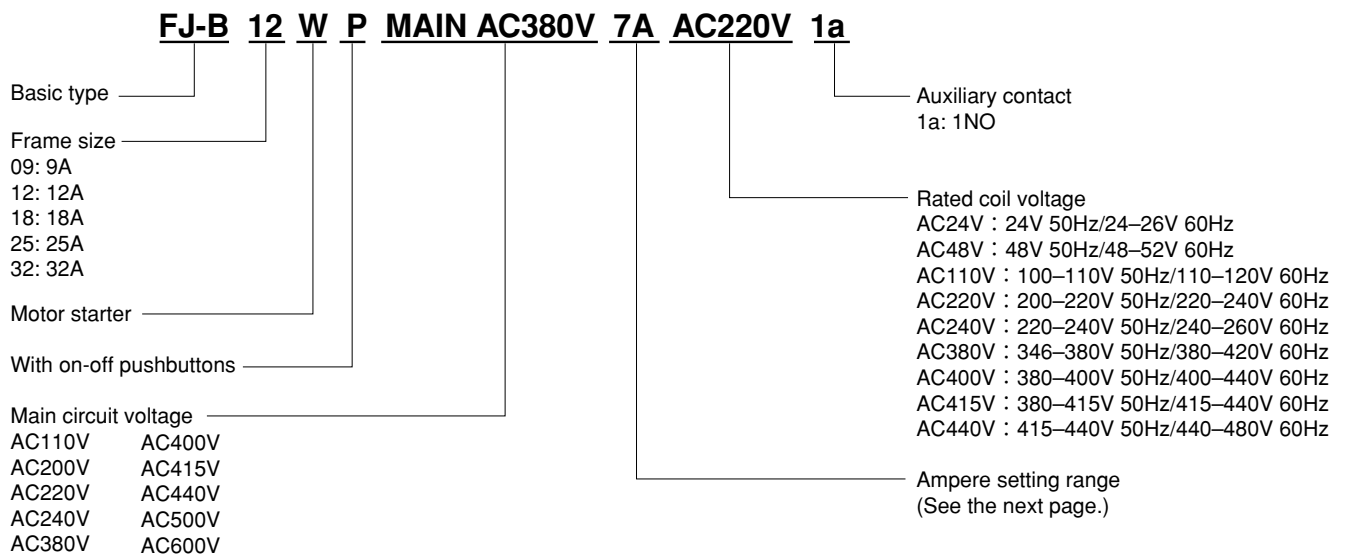

■ Types and ratings

Max. motor capacity (kW)				Rated operational current (A)				Auxiliary contact	Enclosure material	Type	Combined thermal overload relay
Single-phase	3-phase			Single-phase	3-phase						
110V	200V 240V	380V 440V	600V 690V	110V	200V 240V	380V 440V	600V 690V		Standard		
0.4	2.2	4	4	9	9	9	5	1NO	Plastic	FJ-B09WP	TK12B
0.5	3	5.5	5.5	12	12	12	6	1NO	Plastic	FJ-B12WP	TK12B
0.6	4	7.5	7.5	18	18	18	7	1NO	Plastic	FJ-B18WP	TK18B
0.8	5.5	11	7.5	22	25	25	9	1NO	Plastic	FJ-B25WP	TK32B
1.2	7.5	15	7.5	32	32	32	10	1NO	Steel	FJ-B32WP	TK32B

Note: Auxiliary contact and surge suppressor are optional accessories. (Please refer to the next paragraphs.)

Ampere setting range

Setting range code	Ampere setting range				
	FJ-B09WP	FJ-B12WP	FJ-B18WP	FJ-B25WP	FJ-B32WP
0.1A	0.1-0.15	0.1-0.15	0.1-0.15	0.1-0.15	0.1-0.15
0.13A	0.13-0.2	0.13-0.2	0.13-0.2	0.13-0.2	0.13-0.2
0.18A	0.18-0.27	0.18-0.27	0.18-0.27	0.18-0.27	0.18-0.27
0.24A	0.24-0.36	0.24-0.36	0.24-0.36	0.24-0.36	0.24-0.36
0.34A	0.34-0.52	0.34-0.52	0.34-0.52	0.34-0.52	0.34-0.52
0.48A	0.48-0.72	0.48-0.72	0.48-0.72	0.48-0.72	0.48-0.72
0.64A	0.64-0.96	0.64-0.96	0.64-0.96	0.64-0.96	0.64-0.96
0.8A	0.8-1.2	0.8-1.2	0.8-1.2	0.8-1.2	0.8-1.2
0.95A	0.95-1.45	0.95-1.45	0.95-1.45	0.95-1.45	0.95-1.45
1.1A	1.1-1.65	1.1-1.65	1.1-1.65	1.1-1.65	1.1-1.65
1.4A	1.4-2.1	1.4-2.1	1.4-2.1	1.4-2.1	1.4-2.1
1.7A	1.7-2.6	1.7-2.6	1.7-2.6	1.7-2.6	1.7-2.6
2.2A	2.2-3.4	2.2-3.4	2.2-3.4	2.2-3.4	2.2-3.4
2.8A	2.8-4.2	2.8-4.2	2.8-4.2	2.8-4.2	2.8-4.2
4A	4-6	4-6	4-6	4-6	4-6
5A	5-7.5	5-7.5	5-7.5	5-7.5	5-7.5
6A	6-9	6-9	6-9	6-9	6-9
7A		7-10.5	7-10.5	7-10.5	7-10.5
9A		9-13	9-13	9-13	9-13
12A			12-18	12-18	
13A			13-18		
16A				16-22	16-22
20A				20-26	20-26
26A				26-32	

Dimensions, mm

FJ-B09WP
FJ-B12WP
FJ-B18WP
FJ-B25WP

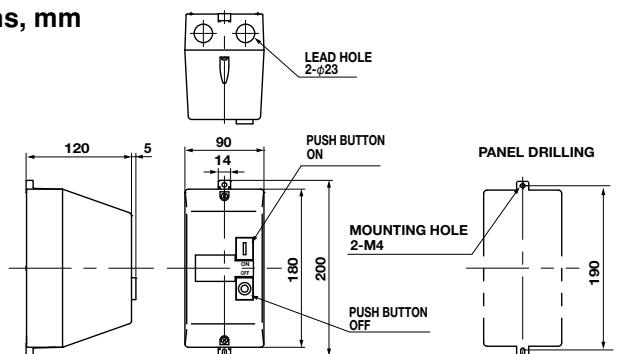

Mass

FJ-B09WP: 0.70kg
FJ-B12WP: 0.70kg
FJ-B18WP: 0.79kg
FJ-B25WP: 0.82kg

FJ-B32WP

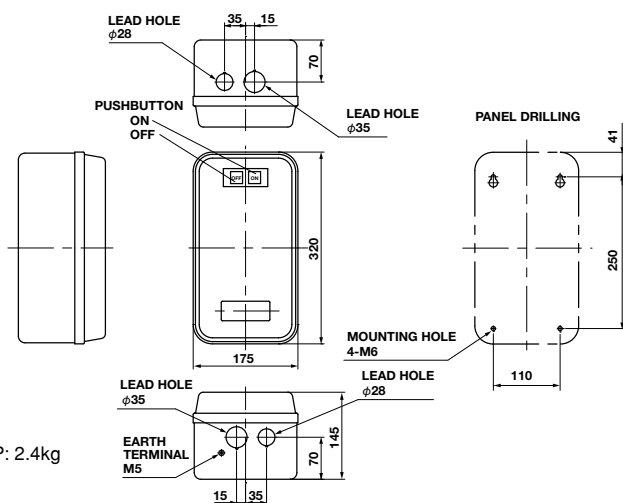

Mass

FJ-B32WP: 2.4kg

Optional unit

Optional unit	Description	Type	Used with
Auxiliary contact block	Front mounting (Bifurcated) 1NO+1NC	SZ1FA11	FJ-B09WP FJ-B12WP
	Front mounting (Single button) 1NO+1NC	SZ1FA11H	
	Side mounting (Bifurcated) 1NO+1NC	SZ-AS1 *1	FJ-B18WP FJ-B25WP
	Side mounting (Single button) 1NO+1NC	SZ-AS1H *1	FJ-B32WP
Coil surge suppression unit	Varistor 24 to 48V AC/DC 48 to 125V AC/DC 100 to 240V AC/DC	SZ1KZ1 SZ1KZ2 SZ1KZ3	FJ-B09WP FJ-B12WP
	Varistor 24 to 48V AC/DC 100 to 240V AC/DC 380 to 440V AC	SZ-Z1 SZ-Z2 SZ-Z3	FJ-B18WP FJ-B25WP FJ-B32WP
	CR (Capacitor-resistor) 24 to 48V AC/DC 100 to 240V AC/DC	SZ-Z4 SZ-Z5	

Note: *1 In case of FJ-B18WP and B25WP, 1 optional unit can be installed, on the left side of the internal magnetic contactor.
In case of FJ-B32WP, maximal 2 optional units can be installed, one on each side of the internal magnetic contactor (left-side and right-side).

Wiring diagrams

FJ-B09WP
FJ-B12WP
FJ-B18WP
FJ-B25WP

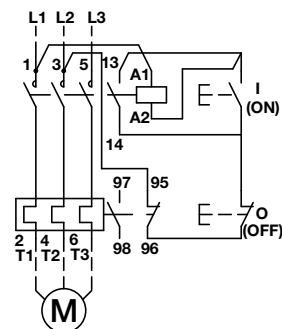

FJ-B32WP

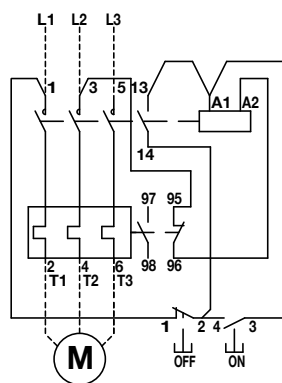

F Fuji Electric FA Components & Systems Co., Ltd.

5-7, Nihonbashi Odetsuma-cho, Chuo-ku, Tokyo, 103-0011, Japan

URL <http://www.fujielectric.co.jp/fcs/eng>